

# SL-50F Precision Piezoelectric Variable Frequency Vibration Feeding Controller

(Built in fiber amplifier and external analog voltage regulating port)

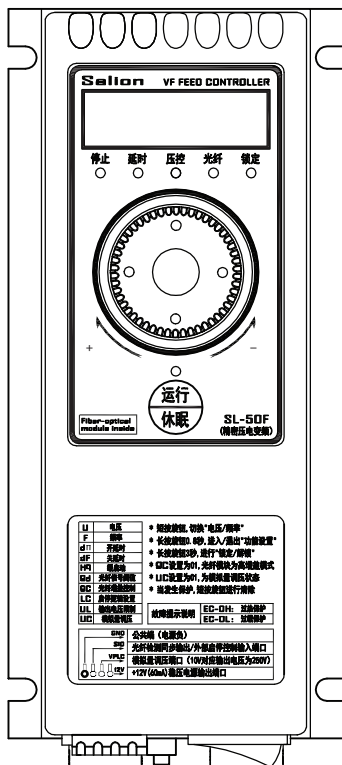

## Product Function Description:

1. Ultimate feeding stability and extremely low feeding noise. Specially designed for high-speed feeding of precision workpieces.
2. Built in high-performance fiber amplifier, patented design, high stability, can accurately detect micro feed workpieces, and can detect no less than 16 feeds per second Workpiece. 999 level photoelectric threshold can be set, real-time monitoring of fiber optic detection values can be achieved, and fiber optic detection threshold signals can be synchronously output.
3. Extremely high driving energy efficiency, energy-saving and environmentally friendly.
4. It can be controlled by PLC or external potentiometer for analog speed control.
5. Single key shuttle operation, patented design, fast and accurate, reliable and durable.
6. Optimized external control interface, flexible and convenient installation and debugging.
7. Intelligent slow start and slow stop, especially in high-speed feeding of precision workpieces, ensure smooth feeding at the moment of start and stop.
8. It can output 12V60mA DC stabilized power supply to power external sensors or speed control potentiometers.
9. Adopting high-performance power devices and excellent circuit design, with extremely low power heat loss, the operation is more stable and reliable.
10. High integration system, optimized external dimensions, light weight, small space occupation, and easy installation.
11. Fully enclosed casing, suitable for harsh working environments.
12. Equipped with undervoltage, overheating, overload, and output short circuit protection.

## Precautions for use:

1. Applicable range of power supply voltage: 85V~265VAC50/60Hz. The input power supply voltage should not exceed 285V, otherwise it will cause irreparable damage
  2. To prevent accidental electric shock accidents, the grounding port of the power plug must be reliably connected, and the power supply must have overcurrent and leakage protection measures
  3. To ensure long-term stable operation, the controller should be avoided from being installed in locations with excessive vibration amplitude
  4. The controller generates heat during operation. To ensure long-term stable operation, the controller is installed vertically in a ventilated area
- To ensure long-term stable operation, avoid any dust or liquid contact with this controller
6. The output port has a ground wire, and the vibration disc must be reliably connected to this ground wire
  7. It is strictly prohibited to use any method of cutting off input power or cutting off power output to control the start/stop of the vibration disc, which will seriously shorten the service life of the controller. Start/stop control signals should be used for start/stop control.
  8. The load current of the 24V DC power output port of the controller cannot exceed 200mA, otherwise it will cause the 24V power supply to disconnect or the parameters cannot be saved.
- To prevent electric shock accidents, it is strictly prohibited to unplug the power output port when the controller is powered on.
10. After all wiring is completed, connect the power input cable and turn on the power switch of the controller.



The vibrating disc body must be reliably grounded, otherwise significant personal injury or property damage may occur. Please confirm that the wiring of each port is reliable before inserting the power cord into the power socket.

## Introduction to operation panel and ports:

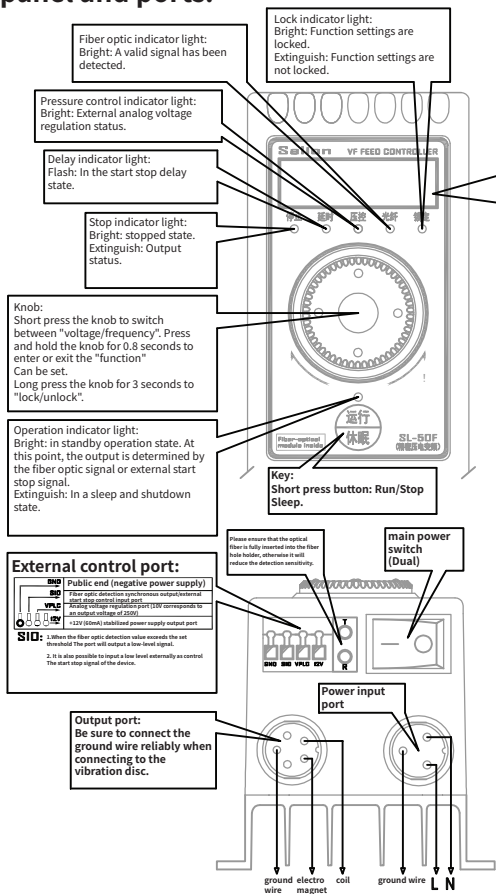

### Parameter setting instructions:

<b>U 080</b>	output voltage
<b>F2000</b>	output frequency
<b>40.0*400.0Hz</b>	Continuing Adjust
<b>d0000</b>	Open delay time
Can set a delay time of 0-99.9 seconds for opening	
<b>dF000</b>	Delay time
Can set a delay time of 0-99.9 seconds for shutdown	
<b>H9030</b>	Slow start time
Can set a slow start time of 0.1-9.9 seconds	
<b>Fd000</b>	Fiber optic detection value
<b>FL200</b>	Lower limit of fiber optic threshold
<b>FH999</b>	Fiber optic threshold upper limit
<b>FC</b>	Fiber optic function settings
<b>9C 02</b>	Optical Fiber Power
<b>9N000</b>	Fiber optic open delay
Can set a delay time of 0-999mS	
<b>9F000</b>	Fiber optic delay time
Can set a delay time of 0-999mS	
<b>LC000</b>	Start stop logic
<b>LFXI</b>	
X1=0: External start stop port X1 is low level shutdown. X1=1: The external start stop port X1 is running at a low level.	
F=0: Fiber optic signal does not participate in shutdown control. F=1: Fiber optic signal participates in shutdown control.	
L=0: F (fiber optic) signal and X1 (external shutdown) logic OR. L=1: F (fiber optic) signal and X1 (external shutdown) logic.	
<b>UL220</b>	Output voltage limit
Can set the upper limit of output voltage	
<b>UC 00</b>	Analog voltage regulation
00: Adjust the pressure with the body knob. 01: External analog voltage regulation (VPLC port) [synchronous output function is invalid when UC=01]	
<b>5Y 00</b>	
00: At runtime, the port has output. 01: When stopped, the port has output. 02: When the fiber optic detection is effective, there is output from the port.	

### Precautions for use:

1. Please confirm that the power input is AC 90-265V.
2. The ground wire must be reliably connected.
3. After completing the wiring, turn on the main power switch.
4. Please avoid installing in machine positions with excessive vibration amplitude.

### Troubleshooting:

No display: Confirm if the power is connected.

**E-0H:** Overheating protection. Install the controller in a ventilated area, and if possible, on a metal machine to facilitate heat dissipation.

**E-0L:** Overload protection. Confirm whether the power of the vibration disc matches the controller and whether the output cable is short circuited

## Quick installation and usage guide:

### Step 1:

Open the outer packaging of the controller, check the appearance and side label model of the controller, and determine if it is the required model.

### Step 2:

Take out the output and input wires, connect the output wires to the electromagnetic coil of the vibration disc, ensure reliable ground connection, plug the aviation plugs of the output and input wires into the controller, and tighten the nuts.

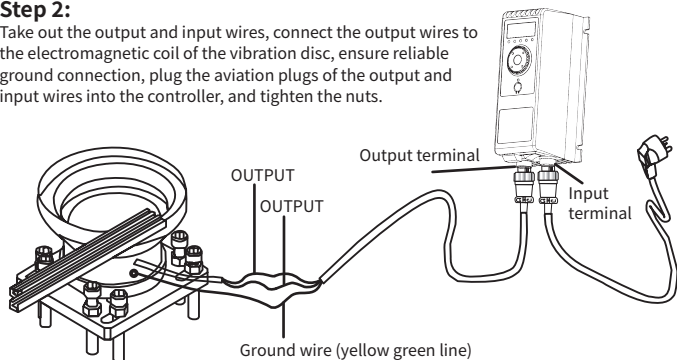

- Be sure to confirm that the electromagnetic coil is connected to both output pins and that the controller heat sink needs to be reliably grounded. Otherwise, it will cause the controller to be subjected to electrostatic shock, which may lead to controller failure. The yellow and green ground wires should be reliably connected, and not connecting them may cause serious safety accidents!!



### Step 3:

Insert the three pronged input plug into the power socket.

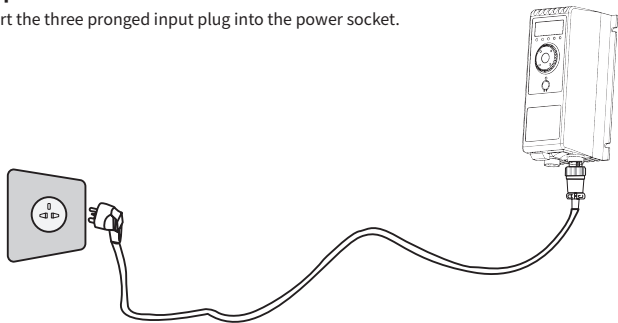

**Step 4:**

Turn on the power switch of the controller and rotate the knob to adjust the output voltage "U" to between 80 and 100.

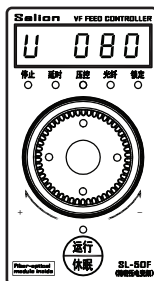
**Step 5:**

Short press the knob to enter the frequency "F" adjustment state; Rotate the knob key to find the natural frequency of the vibrating body, which is commonly referred to as the resonance point.

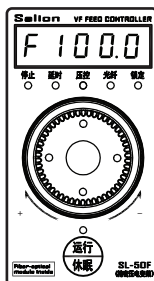

- ◆ The maximum frequency of vibration is the natural frequency of the vibrating body. Each vibrating body has an inherent vibration frequency. In order to achieve the best working state, please adjust this parameter to make the vibrating body work at the appropriate working frequency.

**Step 6:**

After finding the natural frequency of the vibrating body, briefly press the knob to return to the voltage adjustment function and adjust it to the optimal feeding speed.

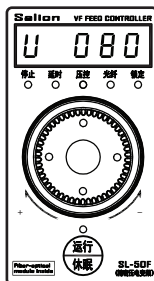

- ◆ To achieve optimal working conditions, please adjust this parameter and increase the 'output voltage' to the desired feeding speed.



## Parameter settings:

### U (output voltage):

By default, the panel displays "U", indicating that it is in the output voltage setting state. At this time, press "+" or "-" to set the range: 0-2 with 1V steps.

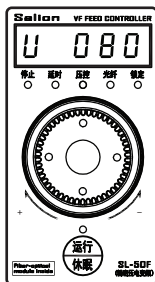

#### Tips:

1. When the output voltage is set high, if the "excitation" indicator light on the panel lights up, it indicates that the current output is in an excitation state, the output voltage waveform is no longer a complete sine wave, and the anti beat frequency capability will be affected.
2. When the output voltage is set high, if the "saturation" indicator light on the panel lights up, it indicates that the current output voltage has reached its limit and the voltage stabilization ability will be affected.
3. This output voltage is limited by the "UL (output voltage limit)" parameter. When "UC" (output voltage control mode)=1, it is an external analog control mode, and the output voltage cannot be set through the "knob" on the panel, and the "lock" LED will flash.

### F (output frequency):

Short press the "knob" and the panel will display "F", indicating that it is in the output frequency setting state. At this time, rotating the "knob" can set the range: 40.0~400.0 Hz, with 0.1 Hz as the step.

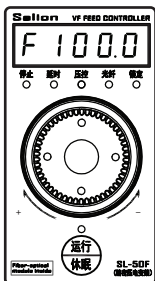

#### Tips:

1. Short press the "knob" again to switch to the "U (output voltage setting)" state.

### Dn (opening delay time):

Press the "knob" for 0.8 seconds to enter the function settings. Rotate the "knob" to select the function parameters until the panel displays "dF". Then press the "knob" briefly, and "dF" will flash. At this time, rotate the "knob" to set the settings. The setting range is 0-30 seconds, with 1 second as the step.

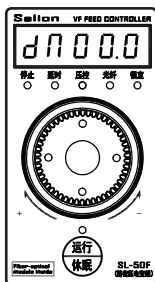

#### Tips:

1. In the running state (running indicator light on), when the signal from the external start stop or photoelectric sensing port meets the starting conditions, it needs to go through a "delay time" before starting the output. At the same time, the "delay indicator light" on the panel will flash.
2. Regarding the operating conditions, please refer to the description of "LC (Start Stop Logic)".

### DF (Off Delay Time):

Long press the "knob" for 0.8 seconds to enter the function settings, rotate the "knob" to select the function parameters until the panel displays "dF", then short press the "knob", and "dF" will flash. At this time, rotating the "knob" can be used for settings, with a setting range of 0.0~999 seconds, with 0.1 seconds as the step.

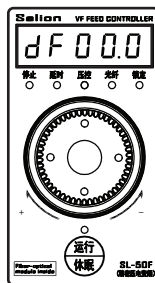

#### Tips:

1. In the running state (with the running indicator light on), when the signal from the external start stop or photoelectric sensing port meets the stop conditions, the output needs to go through a "shutdown delay time" before stopping. At the same time, the "delay indicator light" on the panel will flash.
2. Regarding the stopping conditions, please refer to the description of "LC (Start Stop Logic)".

**Hq (slow start time):**

Long press the "knob" for 0.8 seconds to enter the function settings, rotate the "knob" to select the function parameters until the panel displays "HQ", then press the "knob" briefly, and "HQ" will flash. At this time, rotating the "knob" can be used for settings. The setting range is 0.1~9.99 seconds, with 0.01 seconds as the step.

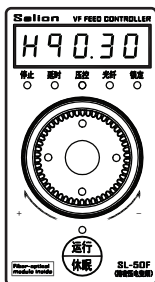
**Tips:**

1. When the controller starts the output, the output voltage will gradually (at the speed of this slow start time) increase linearly from 0V to the set output voltage to eliminate the impact on the vibration plate and prevent the workpiece from falling off.

**Fd (fiber optic detection value):**

Long press the "knob" for 0.8 seconds to enter the function settings, rotate the "knob" to select the function parameters until the panel displays "Fd", which is the value of fiber optic detection.

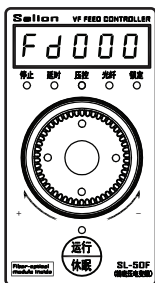
**Tips:**

The value of "Fd" is the value detected by the optical fiber, and the signal output will be generated when the value between the lower limit of "FL" and the upper limit of "FH" is detected.

**FL (lower limit of fiber optic threshold):**

Long press the "knob" for 0.8 seconds to enter the function settings. Rotate the "knob" to select the function parameters until the panel displays "Fd". Short press the "knob" to enter "FL". At this time, rotate the "knob" to make settings, with a range of 0~999.

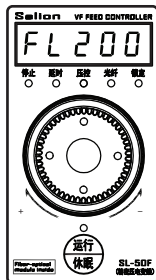
**Tips:**

Set the lower limit value of the "Fd" fiber detection value.

**FH (upper limit of fiber optic threshold):**

Long press the "knob" for 0.8 seconds to enter the function settings, rotate the "knob" to select the function parameters until the panel displays "Fd", short press the "knob" to enter "FL", and then short press the "knob" to enter "FH". At this time, rotating the "knob" can be used for settings, with a range of 0~999.

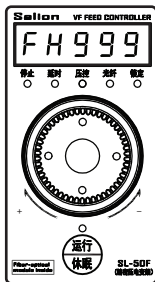
**Tips:**

Setting the upper limit of the "Fd" fiber detection value.

### FC (Fiber Function Settings):

Long press the "knob" for 0.8 seconds to enter the function settings, rotate the "knob" to select the function parameters until the panel displays "FC", which is the fiber optic function setting.

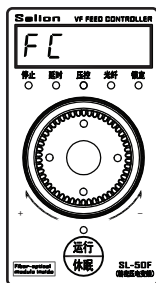

#### Tips:

FC "is the entry point for setting fiber power, on delay, and off delay.

### gC (Fiber Power Setting):

Long press the "knob" for 0.8 seconds to enter the function settings. Rotate the "knob" to select the function parameters until the panel displays "FC". Short press the "knob" to enter "gC". At this time, rotate the "knob" to make settings, with a range of 00~03.

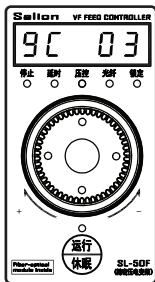

#### Tips:

There are 4 levels in total, with "00" having the weakest fiber power and "03" having the strongest fiber power.

**gn (fiber on delay):**

Long press and hold the "knob" for 0.8 seconds to enter the function settings. Rotate the "knob" to select the function parameters until the panel displays "FC". Short press the "knob" to enter "gn". At this time, rotate the "knob" to make the settings. The setting range is 0~99.9 seconds.

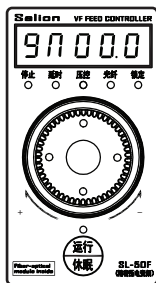
**Tips:**

The "gn" fiber opening delay setting can be set with an opening delay of 0-99.9 seconds.

**gF(Fiber optic delay time):**

Long press the "knob" for 0.8 seconds to enter the function settings, rotate the "knob" to select the function parameters until the panel displays "FC", short press the "knob" to enter "gn", and then short press the "knob" to enter "gF". At this time, rotating the "knob" can be used for setting, with a setting range of 0~99.9 seconds.

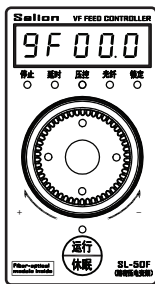
**prompt:**

The "gF" fiber optic turn off time setting can be set with a turn off time of 0-99.9 seconds.

### LC(Start stop logic setting):

Long press the "knob" for 0.8 seconds to enter the function settings. Rotate the "knob" to select the function parameters until the panel displays "LC". Then press the "knob" briefly, and the "LC" will flash. At this time, rotate the "knob" to set the range: 000-111.

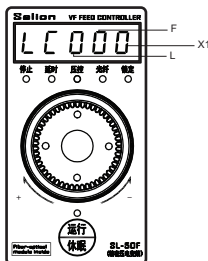

#### prompt:

X1=0: External start stop port X1 is low level shutdown;  
 X1=1: The external start stop port X1 is running at a low level;  
 F=0: Fiber optic signal does not participate in shutdown control;  
 F=1: Fiber optic signal participates in shutdown control;  
 L=0: External shutdown signal and fiber optic signal logic OR;  
 L=1: Logic of external shutdown signal and fiber optic signal.

### UL(Output voltage limit):

Press and hold the "knob" for 0.8 seconds to enter the function settings. Rotate the "knob" to select the function parameters until the panel displays "UL". Then press the "knob" briefly, and the "UL" will flash. At this time, rotate the "knob" to set the range: 0V~220V.

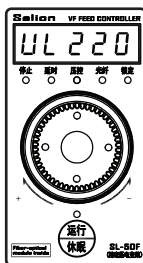

#### prompt:

1. Setting an upper limit value for this parameter can prevent users from accidentally operating and causing the output voltage to be too high, resulting in damage to the vibration disc.
2. When the setting of this parameter is less than "U (output voltage)", "U (output voltage)" will automatically decrease.
3. This parameter is also applicable to the external analog voltage regulation mode.
4. When "UC" (output voltage control mode)=1 and it is an external analog control mode, the UL parameter will automatically adjust the external analog control range: VPLC=0~10V, corresponding to output voltage: 0~"UL".

**UC(Output voltage control mode):**

Long press and hold the "knob" for 0.8 seconds to enter the function settings. Rotate the "knob" to select the function parameters until the panel displays "UC". Then press and hold the "knob" briefly, and the "UC" will flash. At this time, rotate the "knob" to make settings, with a setting range of 0~1.

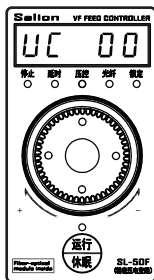
**prompt:**

UC=00: Adjust the output voltage through the "knob" on the panel;  
 UC=01: Adjust the output voltage through an external analog voltage regulator port;  
 When "UC"=1, rotate the "knob" of the panel, and the "lock" indicator light on the panel will flash, indicating that the operation is invalid.

**SY(Synchronous output control):**

Long press the "knob" for 0.8 seconds to enter the function settings, rotate the "knob" to select the function parameters until the panel displays "Sy", then short press the "knob", and "Sy" will flash. At this time, rotating the "knob" can be used for settings, with a range of 0~1.

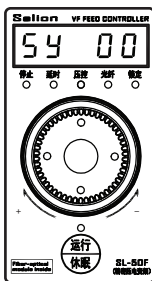
**prompt:**

Sy=0: When the controller is running, the port has an output.  
 Sy=1: When the controller stops, the port has an output.  
 Sy=2: When the fiber optic detection is valid, the port has output.

## External control and fiber port description:

When UC=00, this port is a synchronous output port that can directly drive loads such as solenoid valves and relays. Attention: This port can drive a maximum load of 2A and does not have overcurrent protection. When "UC=01", this port is an analog control voltage input port, and the 10V control voltage corresponds to the voltage set by the "UL" parameter. At the same time, the OUT (synchronous output port) is invalid.

External start stop control signal input port (X1)

Public end (negative power supply)

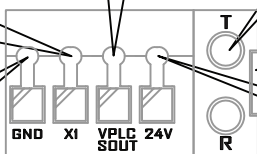

Fiber optic hole holder. The upper hole is a light emission hole, The lower hole is a light receiving hole.

Fiber locking plug: After inserting the fiber into the hole seat, insert this plug to fix the fiber optic cable.

+24V power output port with 200mA overcurrent protection.

## External start stop control port:

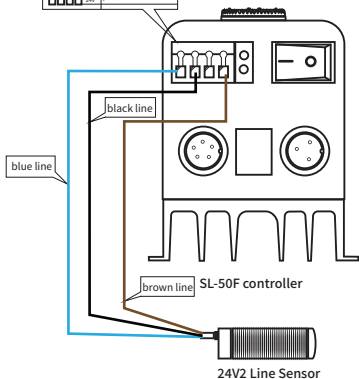
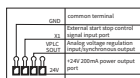

Universal sensor start stop control (NPN three wire)

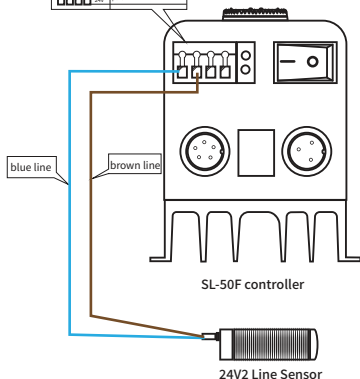
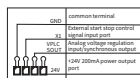

Universal sensor start stop control (NPN two-wire)

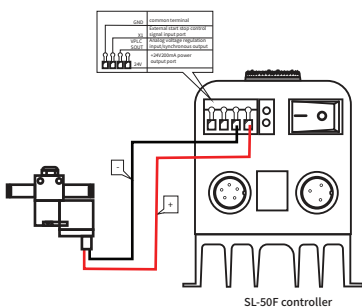

**Synchronous output port drives solenoid valve**

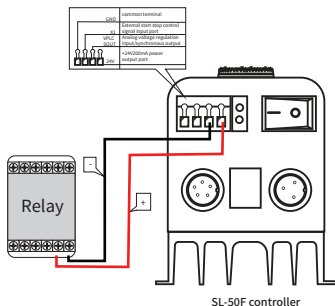

**Synchronous output port drives relay**

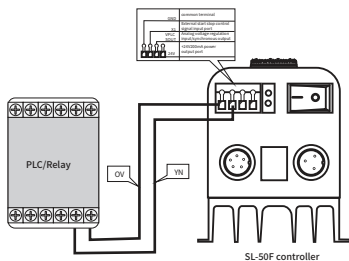

**Relay contacts or PLC output signals are used for start stop control**

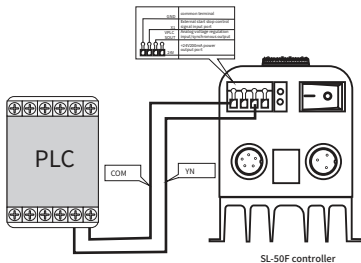

**PLC analog output for output voltage control**

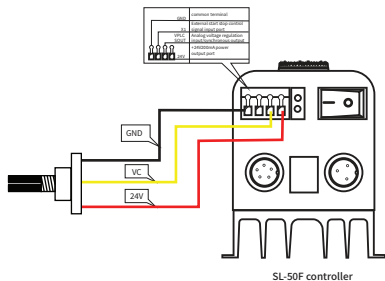

**Potentiometer voltage regulation module for voltage regulation control**

## SL-50F Controller dimensions:

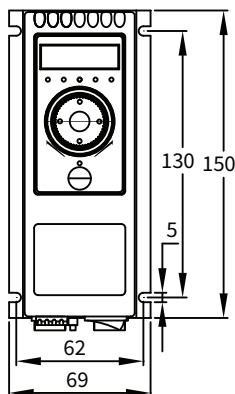

SL-50F (top view)

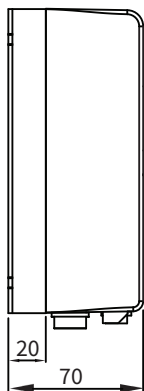

SL-50F (left view)

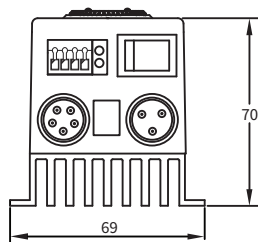

SL-50F (front view)

**prompt:**

SL-50F: 150 (length) \* 69 (width) \* 70 (height)

单位: mm

**Abnormalities and exclusions:**

<b>No display</b>	Confirm if the power is connected and check if the fuse is intact. (Fuse specification: 250V 6.3A fast melting type 5 * 20mm)
<b>EC-0H</b>	Overheating protection. Install the controller in a ventilated area. If possible, install it on a metal machine to facilitate heat dissipation.
<b>EC-0L</b>	Overload protection. Check: whether the gap between the electromagnetic coil and the armature is too large, whether the power of the vibration disc matches the controller, and whether the output cable is short circuited.
<b>EC-0U</b>	Overvoltage protection. Check if the input power supply is 110-220V.
<b>EC-LU</b>	Undervoltage protection. Check if the input power supply is 110-220V.

## Function and parameter description of fiber amplifier:

- The controller is equipped with a set of fiber amplifiers, which can detect 10000 times per second and output 1000 effective detection results per second. It has extremely low temperature drift and wide temperature adaptability (better than 1.5% for 0-40 degrees Celsius and better than 3% for -20~60 degrees Celsius);
- 999 level fiber detection value upper and lower limits (window detection) can be set, and 4 levels (better than 100 times) of optical power adjustment can be performed for workpieces with different reflectivity.

Parameter Code	parameter description
<b>Fd</b>	Display the current detection value of the fiber optic cable.
<b>FL FH</b>	FL: Set the lower threshold; FH: Set the upper limit of the threshold. When the fiber optic detection value is in the FL and FH range, the workpiece detection result is valid.
<b>GC</b>	Optical power setting, consisting of four levels of optical power, is set based on the reflectivity of the workpiece and the distance between the workpiece and the fiber head.
<b>gn gF</b>	gN: Fiber optic on/off delay; gF: Fiber on delay. This parameter is generally used to eliminate detection jitter caused by the diversity and discontinuity of the reflective characteristics of the workpiece itself when supplying fiber optic detection signals to PLC.

## Fiber optic hole holder and applicable fiber optic cable diagram:

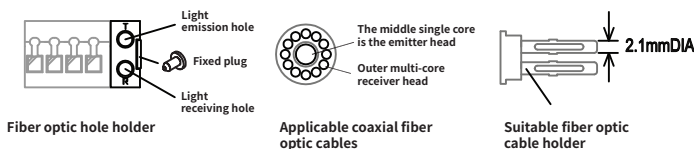

## Precautions for fiber optic cable installation (must be read carefully):

- The applicable fiber optic cable is coaxial fiber optic cable, and it is necessary to distinguish between the transmitting and receiving ends, otherwise it will seriously affect the detection effect;
- Before inserting the fiber optic cable into the fiber optic hole holder, in order to achieve the best detection performance, it is necessary to use the attached "fiber optic cable dedicated cutter" to cut the head of the fiber optic cable flat, and then insert the fiber optic cable into the fiber optic hole holder;
- Install the fiber optic cable after the fiber optic hole holder. To ensure stable and reliable operation, try to avoid repeatedly installing the fiber optic cable;
- X: After installing the 1911.91 mm 4 fiber optic cable, immediately clamp and fix the cable to the controller housing using the attached "fiber optic fixing clip" to prevent the optical Y: 111.49 mm fiber optic cable from being pulled and loosened by excessive external force, which may cause detection function failure;
- Do not excessively bend the fiber optic cable (the recommended bending diameter is greater than 25mm), and avoid damaging the outer surface of the fiber optic cable, otherwise it will seriously reduce the sensitivity and reliability of fiber optic detection;
- When wiring and fixing fiber optic cables, it is necessary to avoid high temperature heat sources, otherwise it will affect the stability of detection;
- When designing and installing fiber optic inspection heads, it is important to understand the following:
  - The detection head should be completely prevented from being hit by the workpiece;
  - Try to keep the detection head away from the airflow of the nozzle, as the airflow can bring dust, water vapor, and even oil stains.
  - To prevent dust adhesion from causing detection failures, the principle of lateral or downward installation angle should be followed, and the possibility of accidental interference from unknown strong light sources from the outside can also be eliminated;
  - The optical fiber must be securely fixed.

## Fiber optic cable installation steps:

1. Check if the end of the fiber optic cable (fiber holder end) is flat. If it is not flat, use the "fiber optic cable dedicated cutter" attached to the fiber optic cable to cut it flat;
2. After pushing the fiber optic cable out of the holder by at least 2mm (as shown in Figure A below), fully insert the fiber optic holder into the fiber optic socket of the controller (ensuring that the transmitter and receiver are distinguished correctly);
3. Fully insert the fiber optic plug into the plug hole on the side of the fiber optic socket (as shown in Figure B below) to securely fix the fiber optic cable;
4. After installing the fiber optic cable in the fiber optic hole seat, in order to ensure stable and reliable operation, try to avoid repeatedly installing the fiber optic cable;
5. Use the attached "fiber optic fixing clip" to clamp and fix the fiber optic cable to the controller housing to prevent the cable from being pulled or loosened by excessive external force, which may cause detection function failure. Installation is complete. If you need to disassemble the fiber optic cable, first pull out the fixing plug (pry it up with a small flathead screwdriver).

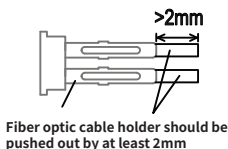

Diagram A

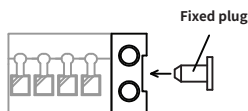

Figure B

## Daily maintenance:

Due to differences in working environments, the fiber optic cable detection head inevitably adheres to dust or stains, affecting the reliability of the detection. Therefore, users need to regularly clean the detection head (especially when equipped with lenses) according to the actual environment. They can use a degreased cotton swab dipped in water to clean it, and must not use chemical solvents for cleaning.

## Standard accessories:

1. Power plug cable
2. output cable
3. instruction manual

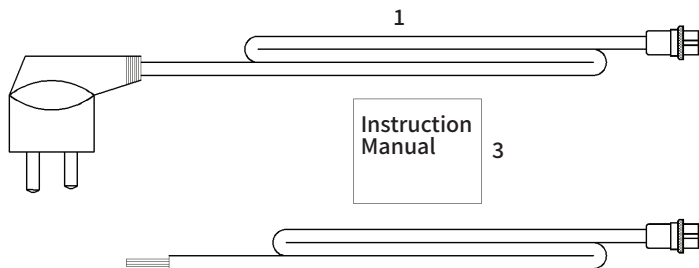

**Optional accessories:**

- |                           |                  |
|---------------------------|------------------|
| 1. Proximity switch (M12) | 2. potentiometer |
| 3. solenoid valve         | 4. fiber optic   |

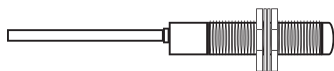

1

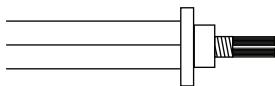

2

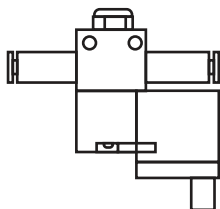

3

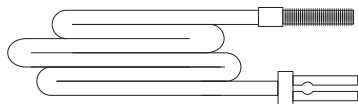

4